

E10

LAMP TYPE: MR16 GU5.3 bi-pin base — Maximum 15 Watts LED, 35 Watts halogen
LED module — Maximum 4 Watts (suitable for indoor use)



WARNING — Risk of Electric Shock. Verify that power is OFF before installing this fixture. This fixture must be installed in accordance with the National Electric Code and local codes. Failure to do so may result in serious personal injury or death. Wiring must be done by a licensed electrician.

For luminaires equipped with *halogen* lamps:

INSTRUCTIONS PERTAINING TO A RISK OF FIRE OR INJURY TO PERSONS IMPORTANT SAFETY INSTRUCTIONS SAVE THESE INSTRUCTIONS

Lighted lamp is HOT!

WARNING – To reduce the risk of FIRE OR INJURY TO PERSONS:

- Turn off/unplug and allow to cool before replacing lamp.
- Lamp gets HOT quickly! Contact only switch/plug when turning on.
- Do not touch hot lens or faceplate.
- Keep lamp away from materials that may burn.
- Do not touch the lamp at any time. Use a soft cloth. Oil from skin may damage lamp.
- Do not operate the luminaire fitting with a missing or damaged faceplate or lens.

This is a low-voltage fixture for use with maximum 25A, 15V power units only. A remote transformer is required. Do not overload the transformer by installing or relamping with higher wattage lamps that together exceed the capacity of the transformer.

The unit low-voltage cable shall: a) be protected by routing in close proximity to the luminaire or fitting, or next to a building structure such as a house or deck; b) not be buried except for a maximum 6 inches (15.2 cm) in order to connect to the main low-voltage cable; and c) have the length cut off so that it is connected to a connector within 6 inches (15.2 cm) from a building structure, a luminaire, or fitting. Contact Beachside Lighting for low voltage cable and direct burial wire for use as main secondary wiring.

- FOR USE WITH LANDSCAPE LIGHTING POWER SUPPLY ONLY
- THIS DEVICE IS ACCEPTED AS A COMPONENT OF A LANDSCAPE LIGHTING SYSTEM WHERE THE SUITABILITY OF THE COMBINATION SHALL BE DETERMINED BY THE LOCAL INSPECTION AUTHORITIES HAVING JURISDICTION
- DO NOT CONNECT TWO OR MORE POWER SUPPLIES IN PARALLEL
- Unless equipped with LED module, LANDSCAPE LIGHTING SYSTEMS ARE FOR OUTDOOR USE ONLY
- NOT FOR USE IN DWELLING UNITS
- A luminaire shall not use tungsten halogen lamps unless the luminaire is marked for such lamps

INSTALLATION

1. Dig a hole 8" diameter by 8" deep at the desired location.
2. Verify that power to fixture is off. Loosen set screws located on Top Plate inside the two oval holes with a 5/64" hex wrench (Figure 2). Lift fixture assembly off the plastic housing and place adjacent to fixture location.
3. Run supply wires up into the bottom of the hole.
4. Place plastic housing into hole with top of the housing flush at grade (Figure 1).

5. Using a 3/32" hex wrench, loosen set screws on either side of the Angling Bracket. Adjust to desired angle and retighten screws (Figure 1).
6. Join fixture leads to wires coming from transformer using silicone-filled wire nuts to ensure proper connection.
7. Fill bottom 4" of plastic housing with pea gravel. Fixture can be set in concrete, but concrete must only be poured AROUND fixture — the bottom must remain open to the earth for drainage.
8. Replace fixture assembly into plastic housing. Rotate as needed to aim lamp, then tighten set screws loosened in Step 2.
9. Back fill hole around the outside of fixture.

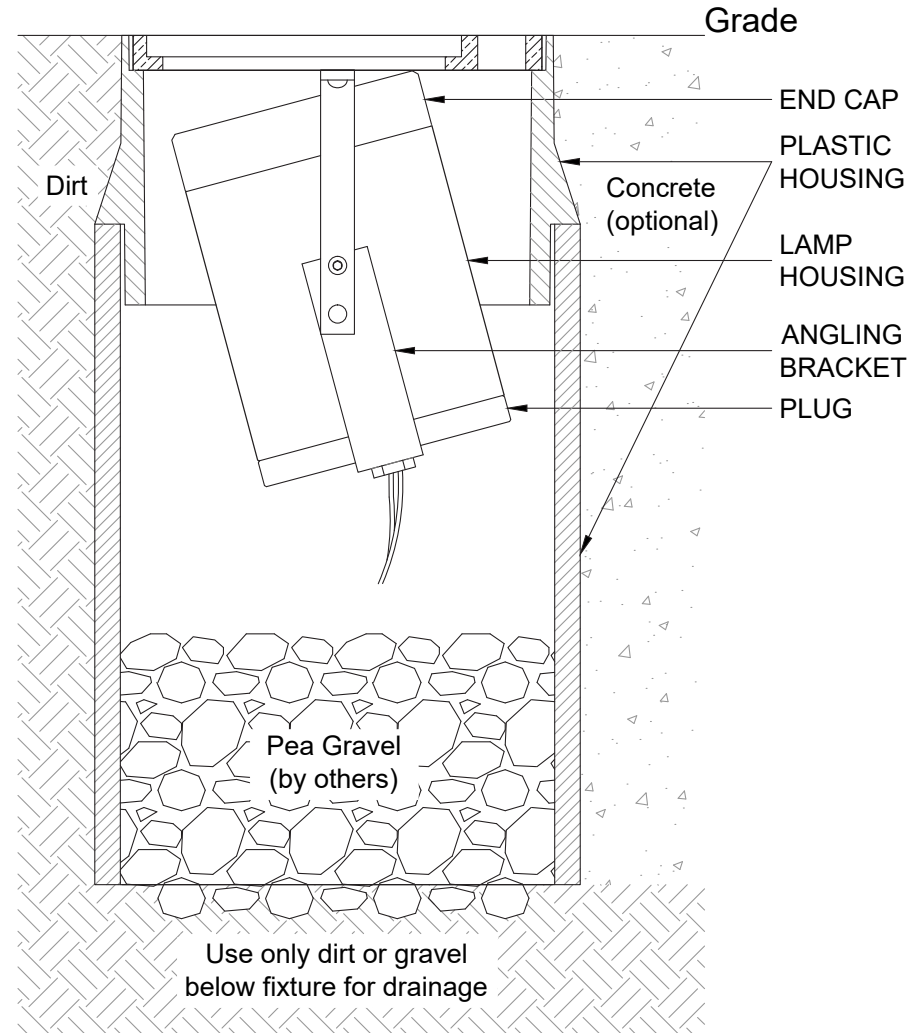

Figure 1

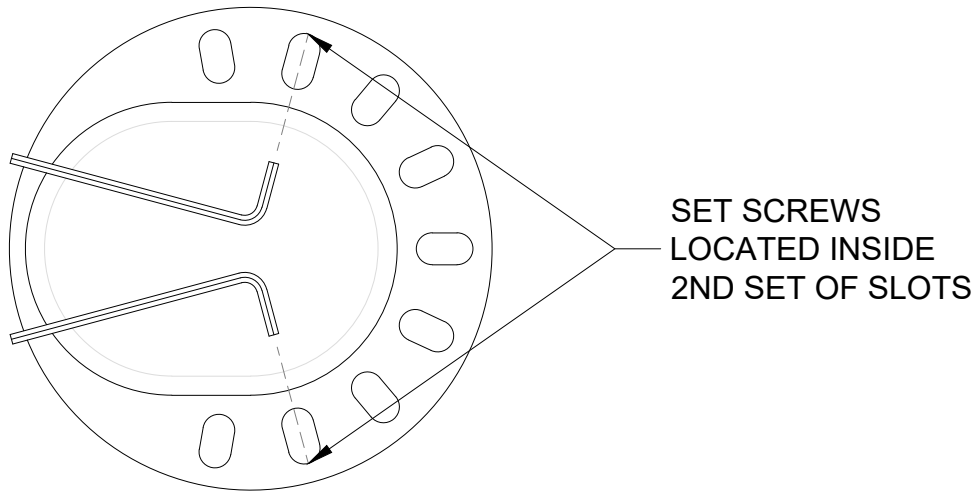

Figure 2

LAMPING - LIGHT ENGINE

This fixture has a long-life LED Module that should not need replacement for years. However, if a Module fails or technology improves and a new one is desired, please contact Beachside Lighting (808-263-5717) for a replacement and instructions.

LAMPING - MR16

1. Make sure power to fixture is OFF.
2. Loosen set screws located on Top Plate inside the two oval holes with a 5/64" hex wrench (Figure 2). Lift fixture off plastic housing and place adjacent to fixture location.
3. Using a 3/32" hex wrench, loosen screws on either side of the Angling Bracket and rotate Bracket so the Lamp Housing faces away from the Top Plate.
4. Unscrew brass Housing from rear brass Plug, exposing the lamp (Figure 3). Do not attempt to separate the End Cap with the glass lens from the cylinder.
5. Pull straight up to remove old Lamp from Socket.
6. Holding replacement lamp at its base, align pins with holes in Socket and insert fully.
7. Reinstall Housing, applying more grease to the o-ring as needed. NOTE: only use lubricant appropriate for silicone rubber.
8. Rotate Angling Bracket back into position and tighten screws.
9. Replace fixture assembly into plastic housing. Rotate as needed to aim lamp, then snug the set screws loosened in Step 2.

TOP PLATE ASSEMBLY WITH HOUSING AND END CAP REMOVED. MR16 LAMP SHOWN.

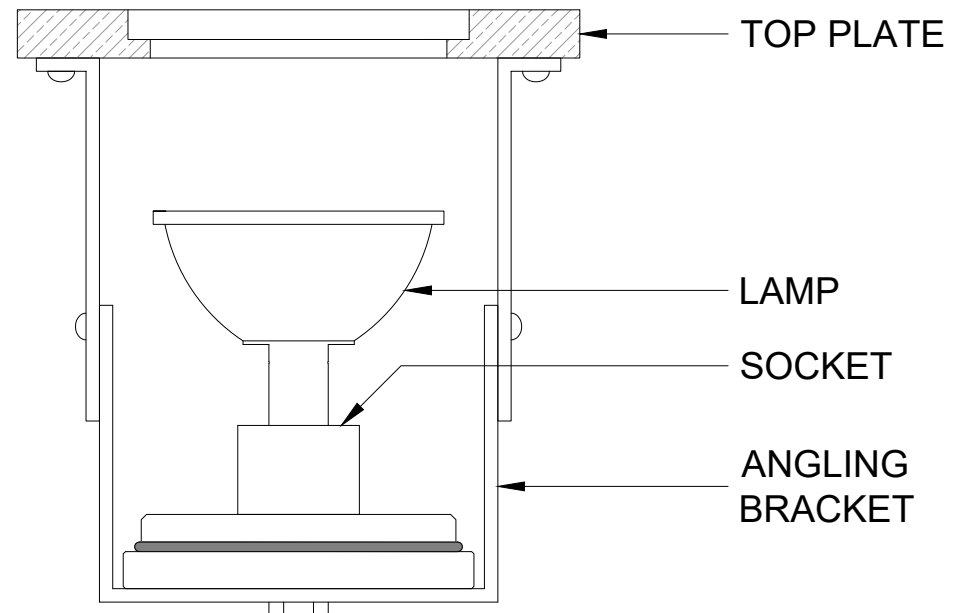

Figure 3



CSA Listed
File # 190030
www.BeachsideLighting.com
808-405-6732

