

# L-011

The L-011 is an unobtrusive, directional fixture available in both low voltage and line voltage configurations. Its compact design brings attention to the lamp's effect, not to the fixture itself. The L-011 can be equipped with several different MR16 LED and halogen lamps and a variety of accessories to produce the desired effect.

**Construction** All brass components • 0.140" [3.6mm] thick brass housing

**Lens** Tempered glass, stepped to prevent pooling of water on lens

**L-011** 12 Volts AC/DC • GU5.3 MR16 LED • Remote Transformer Required  
Amber (1500K), Warm White (2700K/3000K) • Most lamps dim to less than 20%.  
See lamp manufacturer's transformer/dimmer compatibility chart.

5 Watt Cree chipset	___ <b>5W-A-NFL</b>	<b>AMBER (1500K)</b>	25° narrow flood	83 lm	
		<u>2700K</u>	<u>3000K</u>		
Cree chipset 5 Watts	___ <b>5W-SP-27</b>	___ <b>5W-SP-30</b>	15° spot	320 lm	85+ CRI
	___ <b>5W-NFL-27</b>	___ <b>5W-NFL-30</b>	25° narrow flood	320 lm	85+ CRI
	___ <b>5W-FL-27</b>	___ <b>5W-FL-30</b>	40° flood	320 lm	85+ CRI
	___ <b>5W-FL/60-27</b>	___ <b>5W-FL/60-30</b>	60° flood	320 lm	85+ CRI
Lumiled chipset 7 Watts	___ <b>5W-WFL-27</b>	___ <b>5W-WFL-30</b>	100° wide flood	320 lm	85+ CRI
	___ <b>7W-FL/60-27</b>	___ <b>7W-FL/60-30</b>	60° flood	483 lm	90+ CRI
Soraa chipset 8 Watts	___ <b>8W-SP-27</b>	___ <b>8W-SP-30</b>	10° spot	600 lm	90 CRI
	___ <b>8W-NFL-27</b>	___ <b>8W-NFL-30</b>	25° narrow flood	630 lm	90 CRI
	___ <b>8W-FL-27</b>	___ <b>8W-FL-30</b>	36° flood	630 lm	90 CRI

**L-011-120V** 120 Volts GU10 MR16 LED • Amber (1500K), Warm White (2700K/3000K)

**L-011-230V** 230 Volts Most lamps dim to less than 20%. See lamp manufacturer's transformer/dimmer compatibility chart.

5 Watt Cree chipset	___ <b>5W-A-NFL-120V</b>	<b>AMBER (1500K)</b>	25° narrow flood	79 lm	
		<u>2700K</u>	<u>3000K</u>		
Green Creative 5 Watts	___ <b>5W-NFL-27-120V</b>	___ <b>5W-NFL-30-120V</b>	25° narrow flood	390 lm	95 CRI
	___ <b>5W-FL-27-120V</b>	___ <b>5W-FL-30-120V</b>	35° flood	390 lm	95 CRI
Soraa chipset 8 Watts	___ <b>8W-SP-27-120V</b>	___ <b>8W-SP-30-120V</b>	10° spot	600 lm	90 CRI
	___ <b>8W-NFL-27-120V</b>	___ <b>8W-NFL-30-120V</b>	25° narrow flood	630 lm	90 CRI
	___ <b>8W-FL-27-120V</b>	___ <b>8W-FL-30-120V</b>	36° flood	630 lm	90 CRI
	___ <b>8W-WFL-27-120V</b>	___ <b>8W-WFL-30-120V</b>	60° wide flood	630 lm	90 CRI

<b>Optical Accessories</b>	___ <b>BGS</b>	Brass glare shield, 45° cutoff
	___ <b>BGSF</b>	Brass glare shield, full cutoff with weep hole
	___ <b>CTO-1/4-2.04</b>	Color Temperature Orange filter 1/4
	___ <b>CTO-1/2-2.04</b>	Color Temperature Orange filter 1/2
	___ <b>CTO-3/4-2.04</b>	Color Temperature Orange filter 3/4
	___ <b>FR</b>	Frosted lens, 1/8" [3mm] thick
	___ <b>HL1</b>	Honeycomb louver, 1/8" [3mm] thick
	___ <b>HL2</b>	Honeycomb louver, 1/4" [6mm] thick
	___ <b>PR</b>	Prismatic spread lens, 1/8" [3mm] thick
	___ <b>RT</b>	Rectilinear spread lens, 1/8" [3mm] thick
___ <b>SL</b>	Solite (Soft Focus) lens, 1/8" [3mm] thick	
Maximum (2) 1/8" thick accessories or (1) HL2 + (1) CTO Filter		

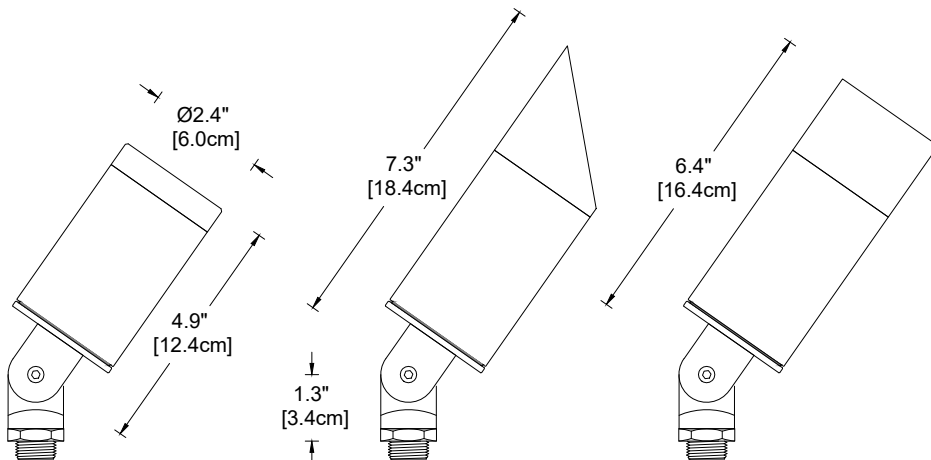

**L-011**



**L-011 with BGS Accessory**



**L-011 with BGSF Accessory**



SUITABLE FOR INDOOR  
USE UP TO 15W LED

# L-011

## Mounting Accessories

1/2" male threads mount into any standard j-box or:

- \_\_\_ **GS2** Heavy-duty ground spike
  - \_\_\_ **GS2BC** Heavy-duty ground spike with cast brass cap
  - \_\_\_ **GS3R** Heavy-duty ground spike with brass cap for telescoping fixture riser
  - \_\_\_ **GS4** \*Standard ground spike with cast brass cap
  - \_\_\_ **JB** Cast brass junction box
  - \_\_\_ **SA** Sure Aim locking rotation accessory (not available with **STEM-S**)
  - \_\_\_ **STEM-C-\_\_** Brass riser for applications where fixture is directed UPWARD (4"/10cm, 8"/20cm, 12"/30cm, 16"/40cm, 20"/51cm or custom height—specify in inches)
  - \_\_\_ **STEM-S-\_\_** Brass riser for applications where fixture is directed DOWNWARD, such as lighting for steps (8"/20cm, 12"/30cm, 16"/40cm, 20"/51cm or custom height—specify in inches).
  - \_\_\_ **TDM1** \*Brass tree/deck mount with stainless steel screws
  - \_\_\_ **TDM2-\_\_** \*Brass tree mount with nylon strap (48, 72, or 96")
  - \_\_\_ **TDM2SS-\_\_** \*Brass tree mount with stainless steel strap (48, 72, or 96")
  - \_\_\_ **TDM3** \*Brass low-profile deck/wall mount (*SA accessory recommended*)
  - \_\_\_ **TDM4** \*Brass low-profile tree mount with notch for wire (*SA accessory recommended*)
  - \_\_\_ **TMJB-\_\_** Brass tree-mounted junction box, single fixture mount, stainless steel strap (48, 72, or 96")
  - \_\_\_ **TMJB2-\_\_** Brass tree-mounted junction box, double fixture mount, stainless steel strap (48, 72, or 96")
  - \_\_\_ **TMJBX** Brass tree-mounted junction box, single fixture mount, stainless steel screws
  - \_\_\_ **TMJB2X** Brass tree-mounted junction box, double fixture mount, stainless steel screws
- \* For 12 Volt only



**L-011-STEM-C-12**



**L-011-STEM-S-12**

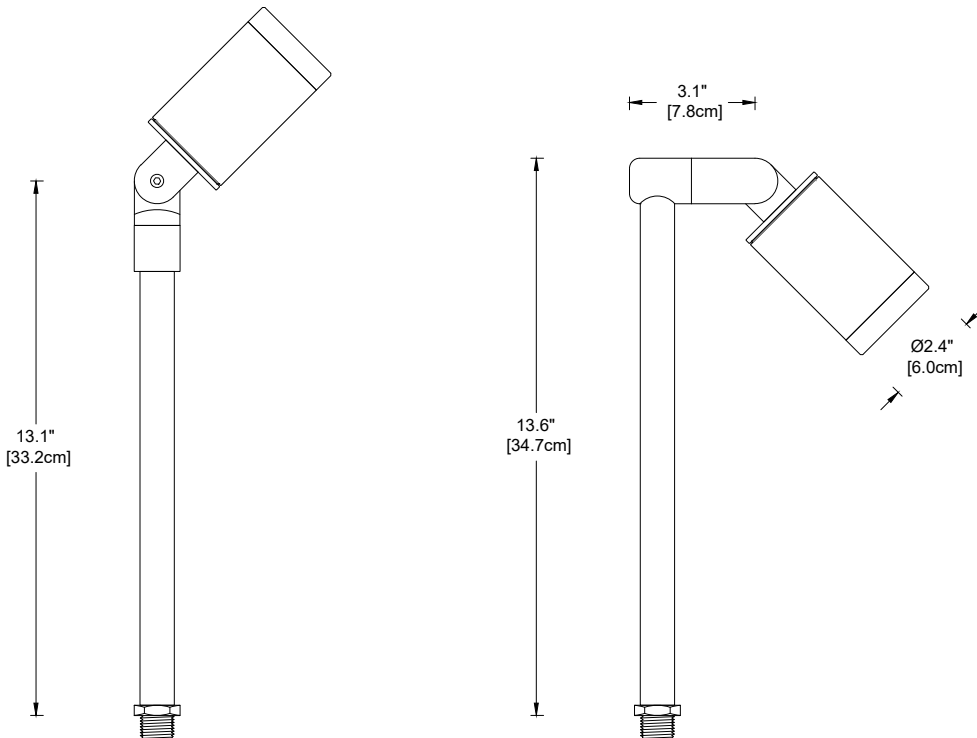

**Fixtures shown on 12-inch stems**

**Finish:** Unfinished is standard; no specification required. The fixture will weather to a natural patina. The patina process is natural with brass and copper. Rate of patina and eventual color is dependent upon climate and proximity to the ocean. Thus, Beachside does not guarantee any specific appearance.

**Weight:** 2.6 lbs. [1.2 kg]  
(excludes Mounting Accessories)

**IP 66**  
CSA Listed, file #190030  
10 year fixture warranty  
3 year warranty on MR16 LED lamps

Project	By	Date
For ordering purposes, please specify (example: L-011-120V—8W-NFL-27-120V—BGS—CTO-1/2-2.04—HL1—GS2—STEM-C-12)		
<b>L-011-</b>		
Fixture	Lamp	Accessory
		Accessory
		Accessory
		Accessory
		Accessory